

DESCRIPTION

Dual Flush Intelligent Toilet
 Multi-Function w/ Remote
 White Finish
 Water Sense Certified
 Complies with cUPC Standards



MEASUREMENTS

SIZE

27.56" x 15.47" X 18.74"

All dimensions are approximate +/-5mm

Structure measurements must be verified against the unit to ensure proper fit.

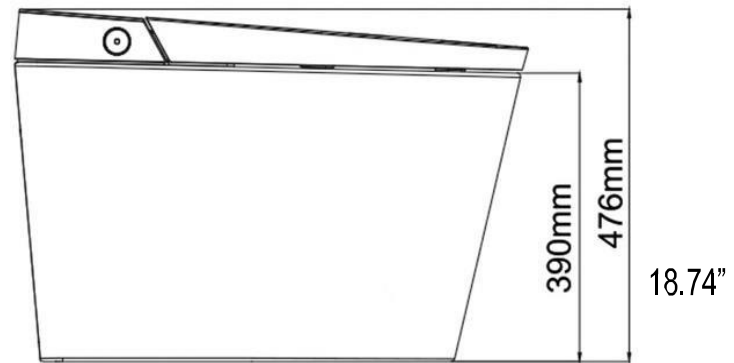
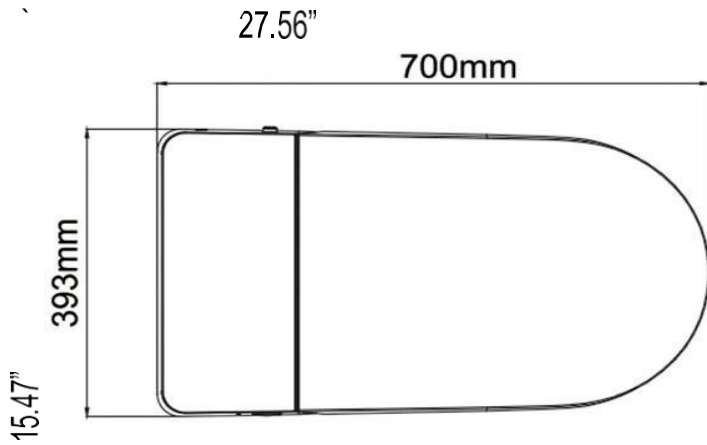

Side button
 Electronically controlled flushing method A:
 Press the side button to flush.



Remote control
 Electronically controlled flushing method B:
 Use the remote control to flush.



Sitting
 Electronically controlled flushing method C:
 After leaving the seat, the toilet (full) flushing function can be automatically activated.



Foot sensor
 Foot sensing flushing method D:
 Foot sensor for half flushing.

1. Main Function

Heating	Instant heating				
Cleaning functions	rear wash	●	Anti-bacterial	anti-bacterial seat	●
	feminine wash	●		anti-bacterial nozzle	●
	mobile wash	●	Remote control	IR remote control	●
	water temperature adjustment	●	Flushing	off-seat flushing	●
	water pressure adjustment	●		button control flushing	●
	nozzle position adjustment	●		remote control flushing	●
	nozzle self-cleaning	●		foot sensor flushing	●
Seat functions	heated seat	●	Control	side button	●
	seat temperature adjustment	●		remote control	●
	seat sensor	●	Deodorization	non photocatalyst deodorization	●
Drying functions	warm air dryer	●	Open and close	slow close (damper)	●
	air dryer temperature adjustment	●		auto open lid, foot sensing open ring	◉
Night light	sensing night light	●		remote control open lid and ring	◉
	on/off	●			



1. "●" means this function is available, "◉" means this function is optional;

2. Technical Specification



name		AA-K-G19 smart one-piece toilet
Main unit	Rated voltage	AC 110V, 60Hz
	Rated power	1070W
	Water pressure range	Static pressure 0.14Mpa (dynamic pressure 0.09Mpa)-static pressure 0.8Mpa
	Waterproof	IPX4
	Power cable	2m length cable, electric leakage protection plug
Cleaning device	Heating	Instant heating
	Heating power	1600W
	Anti-bacterial material	anti-bacterial nozzle
	Water temperature	6 gears adjustment, over heating protection
	Water volume	3 gears adjustment
	Cleaning mode	Rear wash/mobile wash, feminine wash/mobile wash
	Cleaning position	5 gears adjustment
	Water pressure protection	Voltage stabilizing device, automatic pressure relief device
Antifouling device	Automatic nozzle cleaning, anti-siphon, anti-backflow, filter devices	
Drying device	safety device	Thermal fuse, water temperature sensor, grounding protection, electric leakage protection plug
	Wind speed	≥0.2m ³ /min
	Wind temperature	6 gears adjustment
	Heating power safety device	250W Bimetallic thermostat, thermal fuse, leakage protection plug
Heated ring	Seat temperature	6 gears adjustment
	Heating power	50W
	Open and close	slow close/auto open lid
	Anti-scald safety device	After sitting for 10 minutes, the seat temperature will automatically decrease to a low level
	Anti-bacterial material	Seat sensor, temperature sensor, thermostat, temperature fuse, electric leakage protection plug
Smart setting	Anti-bacterial material	Anti-bacterial seat
	Night light	smart night light, on / off
	Deodorization	non photocatalyst deodorization